



Certificate of Calibration

We hereby certify that this product has been calibrated and found to be in accordance with the applicable SPECIFICATIONS and STANDARDS.

Accuracies of the standard equipment used in this calibration are traceable to the National Standards.

MECO METERS PVT. LTD.

Plot No. EL-60, MIDC Electronic Zone, TTC Industrial Area, Mahape, Navi Mumbai - 400710 (INDIA)

Tel : 0091-22-27673311-16, 27673300 (Board)

Fax : 0091-22-27673310, 27673330

E-mail : sales@mecoinst.com

Web : www.mecoinst.com

SR. NO. : _____

CHECKED BY : _____

DATE : _____

MODEL NO. : _____



POWER AND HARMONICS ANALYZER MODEL : PHA5850 USER MANUAL

 EN 61010-2-032
CAT III 600V
Pollution Degree 2

Definition of Symbols :

 Caution : Refer to Accompanying Documents

 Caution : Risk of Electric Shock

 Double Insulation

Over-voltage Category III (CAT III) :
Equipment in fixed installations.

WARNING :
If the clamp meter is used in a manner Not specified by the manufacturer, the protection Provided by the clamp meter may be impaired.

Please read the following instructions before usage

1. Do not operate in wet or dusty environments.
2. Do not operate in presence of combustible or explosive gas
3. Do not touch exposed metal parts, unused terminals.
4. Consider the use of rubber glove In operation.
5. Do not operate in excess of AC 500V (Phase to Neutral), or AC 600V (Phase to Phase)
6. Do not operate when the unit seems to be mal-functioning

Don't use the flexible current probe before you read the following instructions.

1. Don't install the flexible current probe around bare conductors carrying a voltage from 30V to 600V unless you are wearing protective clothing and glove suitable for high-voltage work.
2. Always inspect and check any damage of the current probe assembly before usage. Don't use the flexible current probe if any damage is found.
3. Don't use the flexible current probe on circuit rated higher than 600V in installation category III.

TABLE OF CONTENTS

I. FEATURES 6

II. PANEL DESCRIPTION 7

CURRENT PROBE 12

III. OPERATING INSTRUCTIONS 15

 III.0. Set up before operation 17

 III.1. Power Quality of a 3 Phase 4 Wire System 19

 III.2. Power Quality of a 3 Phase 3 Wire System 21

 III.3. Power Quality of a Single Phase System 23

 III.4. Power Quality of a 1 Phase 3 Wire System 24

 III.5. Measurement of a System with CT or VT 25

 III.6. Harmonic Analysis of Voltage or Current 27

 III.7. Display the Phase Angle of Harmonics 29

 III.8. Measurement of Maximum Demand 30

 III.9. Waveform of Voltage and Current 31

 III.10. Waveform of Voltage Only 32

 III.11. Graphic Phasor Diagram 33

 III.12. Phase Sequence of a 3 Phase System 35

 III.13. Balance and Unbalance 3 Phase (3P3W, 3P4W) Power Source System 36

 III.14. Balance and Unbalance 3 Phase (3P3W or 3P4W) Load System 37

 III.15. Transient Capture (Dips, Swells, Outage) 38

 III.16. Down Load Transient Data 41

 III.17. Data Logging of Power Data (3P4W, 3P3W, 1P2W, 1P3W) 42

 III.18. Down Load Power Data 43

 III.19. Data Logging of Harmonics 44

 III.20. Down Load Harmonics Data 45

IV. HARDCOPY OF SCREEN 46

V. READ THE SAVED SCREEN 47

VI. SET THE CT AND VT RATIO 48

VII. SET THE TIME INTERVAL FOR MAXIMUM DEMAND 49

VIII. SET THE SAMPLING TIME FOR DATA LOGGING ... 50

IV. SET THE CALENDER CLOCK 51

X. PROTOCOL OF RS-232C INTERFACE 51

XI. SPECIFICATIONS (23°C ± 5°C) 52

XII. BATTERY REPLACEMENT 61

XIII. MAINTENANCE & CLEANING 62

XIV. NOMENCLATURE 63

1. FEATURES

- Analysis for 3P4W, 3P3W, 1P2W, 1P3W
- True RMS value (V_{123} and I_{123})
- Active Power (W, KW, MW, GW)
- Apparent and Reactive Power (KVA, KVAR)
- Power Factor (PF), Phase Angle (ϕ)
- Energy (WH, KWH, KVARH, PFH)
- Current measurement from 0.1mA to 1000A, capable of analyzing IT standby power consumption to the maximum demand of a factory
- Display of 35 Parameters in One Screen (3P4W)
- Programmable CT (1 to 600) and PT (1 to 3000) Ratios
- Display of Overlapped Voltage and Current Waveform
- Average Demand (AD in W, KW, MW)
- Maximum Demand (MD in KW, MW, KVA, MVA) with Programmable Period
- Harmonic Analysis to the 99th Order
- Display of 50 Harmonics in one Screen with Waveform
- Display of Waveform with Peak Values (1024 Samples / Period)
- Analysis of Total Harmonic Distortion (THD-F)
- Graphic Phasor Diagram with 3 Phase System Parameters
- Capture 28 Transient Events (Time+ Cycles) with Programmable Threshold (%)
- DIP, SWELL and OUTAGE are included in transient events.
- 3 Phase Voltage or Current Unbalance Ratio (VUR, IUR)
- 3 Phase Voltage or Current Unbalance Factor (d0%, d2%)
- Calculated Unbalanced Current through Neutral Line (In)
- 512K Memory with Programmable Interval (Sampling time from 2 to 3000 seconds, 17000 records for 3P4W system)
- Output of Waveform, Power Parameters and Harmonics at Command
- Large Dot Matrix LCD Display with Backlight
- Optical Isolated RS-232C to USB Interface
- Built in timer and calendar for data logging



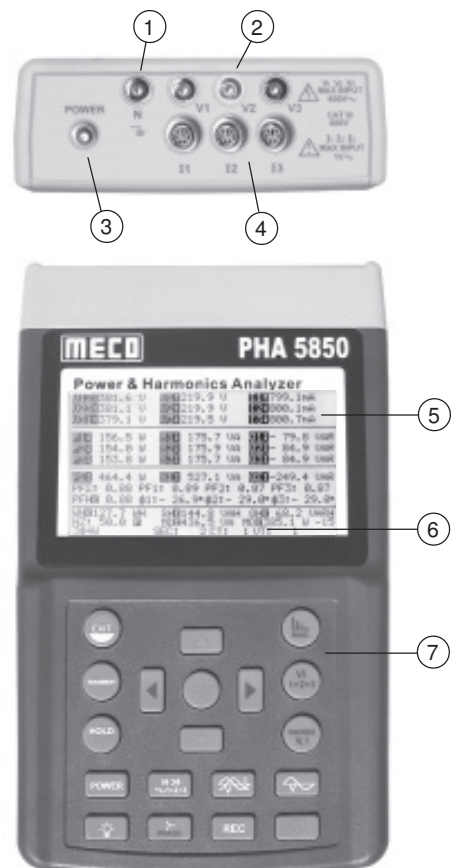

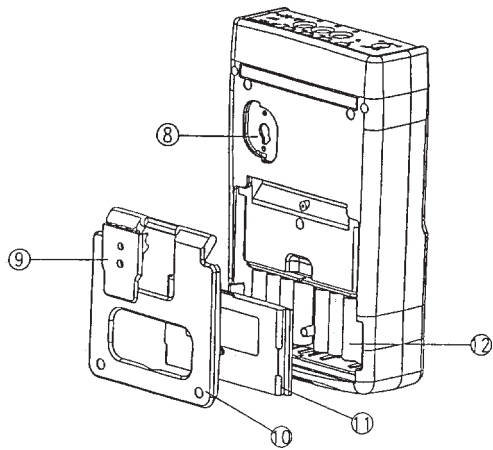
II. PANEL DESCRIPTION



















1. Input Terminal for Neutral Line (Voltage)
2. Voltage Input Terminals for Each Phase (V1, V2, V3)
3. External DC 12V Input (The AC adaptor must be 600V isolated)
4. Current Input Terminals for Each Phase (I1, I2, I3)
5. LCD Display
6. Setting in LCD Screen
7. Buttons
8. RS-232C Window
9. Stand Holder
10. Stand
11. Battery Cover
12. Battery Compartment



-  Press this button to exit transient detection
-  Press this button to perform transient detection
-  Press this button to hold the data displayed in LCD, press again to continue operation.
-  Press this button to start measurement of harmonics is magnitude.

-  Press this button to select V1, I1, V2, I2, V3, or 13 for harmonics analysis
-  Press this button for the voltage or current input range
-  Press this button to select the parameter to be adjusted
-  Press this button to increment value by one. Hold the button for two seconds or more to speed up the increment.
-  Press this button to decrement value by one. Hold the button for two seconds or more to speed up the increment.
-  In the mode of harmonic analysis, press this button to move the cursor left to the previous order.
-  In the mode of harmonic analysis, press this button to move the cursor right to the previous order.

-  Press this button to start to data logging. Press it again to stop logging. The sampling interval is displayed in LCD pointed by indicator.
-  In the mode of power measurement, press this button to display the phasor diagram. In the mode of harmonic analysis, press this button to display phase angle instead of magnitude.
-  Press this button to turn the back light on. Press it again to turn the back light off.
-  Press this button to start measurement of power parameters.
-  Press this button to display waveform of voltage and current.
-  Press this button to display waveform of voltage only.
-  In the mode of power parameter measurement, press this button to select appropriate system (3P4W, 3P3W, 1P2W or 1P3W) the mode of displaying waveform, press this button to select (I1), (V2, I2) or (V3, I3).
-  Press this button to turn the power on or off.

PHA5850 Current Probe 'A' (1/10/100A AC)

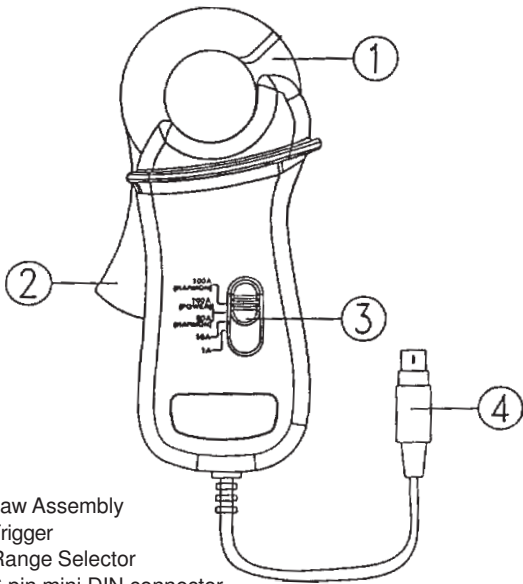

- 1. Jaw Assembly
- 2. Trigger
- 3. Range Selector
- 4. 6 pin mini DIN connector



NOTE : To setup 100A current probe as selected probe, press the SETUP button to select CLAMP. When the CLAMP is reverse video, press the ▲ or ▼ button to select 100.

PHA5850 Current Probe 'B' (10/100/1000A AC)

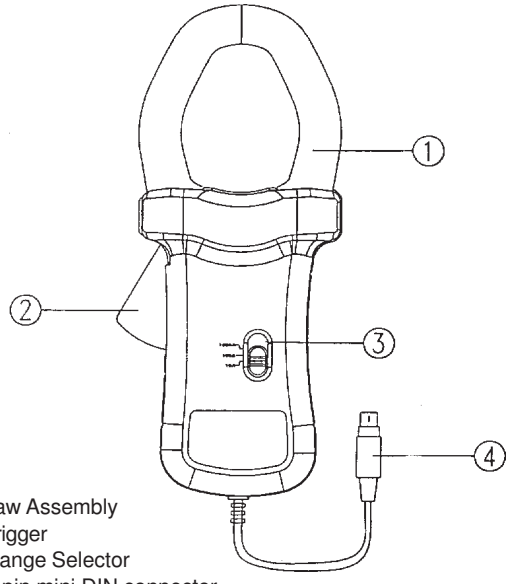

- 1. Jaw Assembly
- 2. Trigger
- 3. Range Selector
- 4. 6 pin mini DIN connector



NOTE : To setup 1000A current probe as selected probe, press the SETUP button to select CLAMP. When the CLAMP is reverse video, press the ▲ or ▼ button to select 1000.

PHA5850 Flexible Current Probe 'C' (300/3000A AC)

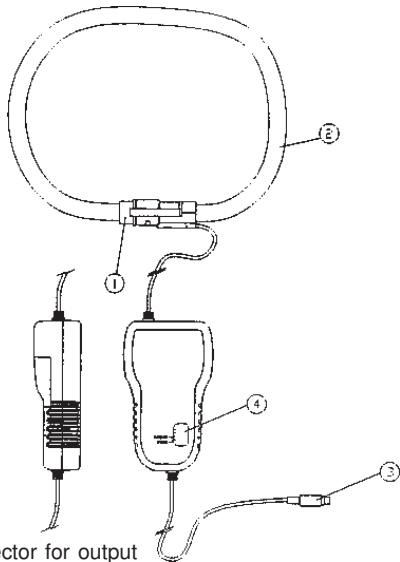

- 1. Coupling Assembly
- 2. Flexible Loop
- 3. Mini-Din connector for output
- 4. Output switch



NOTE : To setup 3000A current probe as selected probe, press the SETUP button to select CLAMP. When the CLAMP is reverse video, press the ▲ or ▼ button to select 3000.

III. Operating Instructions

NOTE : Select the correct clamp in the setup menu. When the current probe is connected to the power analyzer, power analyzer will automatically detect the range selected.

NOTE : Select the correct frequency (Hz) in the setup menu.

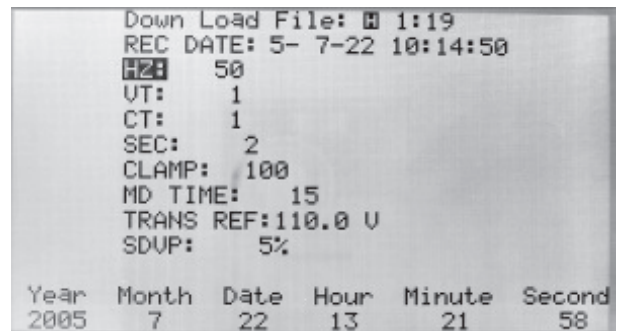

WARNING : All the current probes connected to the power analyzer must be of the same model and same range. Mixed models and different ranges selected will cause incorrect result of measurement.

NOTE : Please pay special attention to the flexible current probes connected to power analyzer.

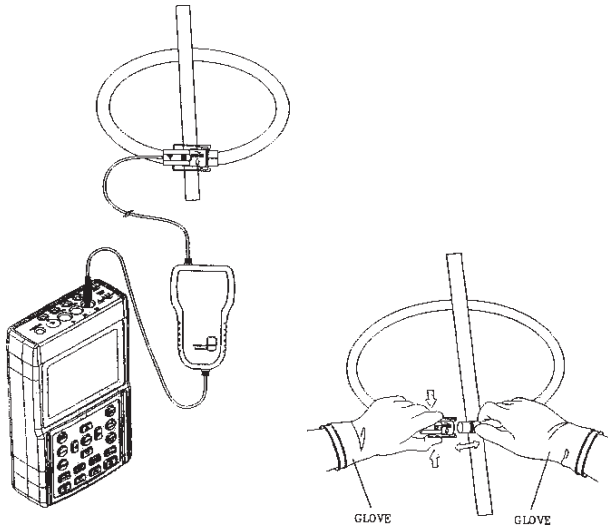

1. Connect the flexible probes around the conductor.
2. Make sure the current flowing direction is in consistent with the arrow marked on the probe coupling. If the flexible current probe is connected in the right orientation, the correct phase will be displayed in the oscilloscope.
3. Keep the probe coupling more than 25mm away from the conductor.

WARNING : Always wear appropriate gloves in operation.

16

III.0. Setup before operation

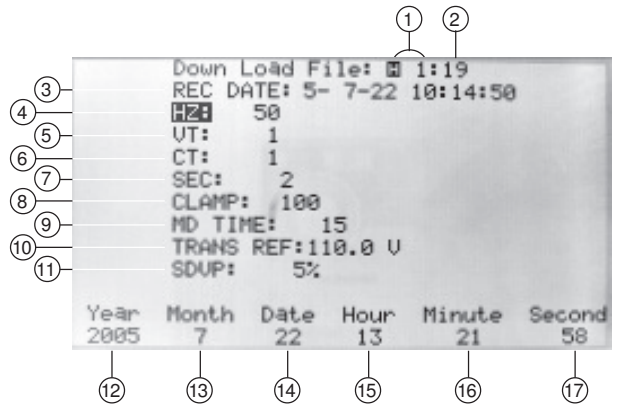

- A. Press **setup** button to enter setup screen. Press **setup** again to select the item for setting (the selected item will be displayed in reverse video).
- B. After selecting the item, press **▲** or **▼** button to leave setup mode.
- C. After finishing setting up, press **exit** button to leave setup mode.

1. Select the data for download

H means harmonics.

H in reverse video means **hold** screen data (if the data is the one you want, you can press **hold** button to display the data and press **hold** button again to exit).

P means power data which can be reference for downloading, the data in order is 0~84.

17

2. Show the total logged data in the analyzer max. 85 logging data.
3. **Rec Date** : show the starting logging time of the 1st downloaded file.
4. **Hz** : setup the frequency (50, 60 and auto) of the system.
5. **PT** : setup PT value
6. **CT** : setup CT value.
7. **Sec** : setup the interval seconds of logged data.
8. **Clamp** : setup the clamp selected (100A, 1000A or 3000A)
9. **MD Time** : setup the time of maximum demand (1~60 min)
10. **Trans Ref** : setup the transient voltage (which will be automatically changed in accordance with PT)
11. **SDVP** : setup upper and lower limits % of transient voltage detection.
12. **Year** : setup year of calender clock.
13. **Month** : setup month of calender clock.
14. **Date** : setup date of calender clock.
15. **Hour** : setup hour of calender clock.
16. **Minute** : setup minute of calender clock.
17. **Second** : Second can displayed only (it can not be adjusted).

18

III.1. Power Quality of a 3 Phase 4 Wire (3P4W) System

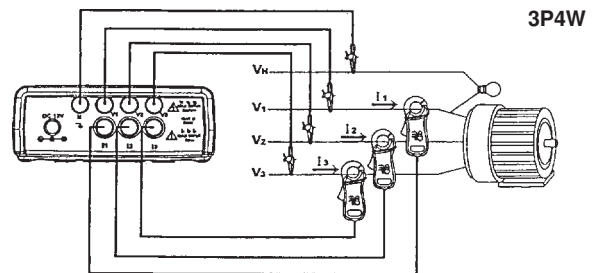

- a. Turn the power on. Press the **POWER** and the **1φ3φ** buttons to select the 3P4W system. The type of system will be displayed at the left bottom corner in the LCD.
- b. Connect the four test leads to the voltage terminals V1, V2, V3 and the V_N (Neutral) of the system.

19

- Connect the test leads to L1, L2, and L3 of the 3P4W system.
- Connect the three current probes to the power analyzer input terminal I1, I2, and I3.
- Clamp on to the L1, L2, and L3 of the 3P4W system. Make sure the current flow from the front of the current probe to the back of it.
- All parameters of the system will be shown in LCD.

U1: 381.6 V	U2: 219.9 V	I1: 799.1 mA
U2: 381.1 V	U3: 219.9 V	I2: 800.1 mA
U3: 379.1 V	U4: 219.5 V	I3: 800.7 mA
P1: 156.5 W	S1: 175.7 VA	Q1: -79.8 VAR
P2: 154.0 W	S2: 175.9 VA	Q2: -84.9 VAR
P3: 153.8 W	S3: 175.7 VA	Q3: -84.9 VAR
PΣ: 464.4 W	SΣ: 527.1 VA	QΣ: -249.4 VAR
PFΣ: 0.88	PF1: 0.89	PF2: 0.87
PFH: 0.88	φ1: -26.9°	φ2: -29.0°
φ3: -29.0°	WH: 127.7 WH	SH: 144.8 UAH
QH: 68.2 VARH	HZ: 50.0 Hz	MD: 436.5 VA
MD: 385.1 W	-15	3φ4W
SEC: 2	CT: 1	UT: 1

For the meaning of each parameter, refer to XIV. Nomenclature.

III.2. Power Quality of a 3 Phase 3 Wire (3P3W) System

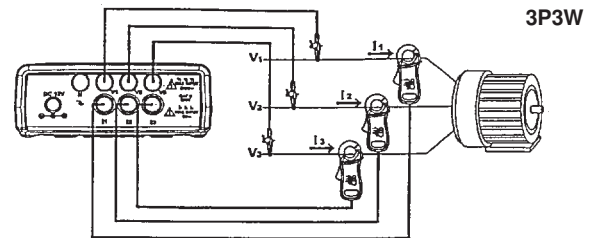

- Turn the power on. Press the POWER and the 1φ3φ buttons to select the 3P3W system. The type of system will be displayed at the bottom right of the LCD.
- Connect the four test leads to the voltage terminals L1, L2 and L3 of the system.
- Connect the test leads to L1, L2 and L3 of the 3P4W system.
- Connect the three current probe to the power analyzer input terminal I1, I2 and I3.
- Clamp on to the L1, L2 and L3. Make sure the current flow from the front of the current probe to the back of it.
- All parameters of the system will be shown in LCD.

U1: 381.1 V	I1: 799.2 mA
U2: 381.4 V	I2: 800.6 mA
U3: 379.6 V	I3: 801.0 mA
PΣ: 464.6 W	SΣ: 527.4 VA
QΣ: -249.7 VAR	PFΣ: 0.88
PFH: 0.88	WH: 9.8 WH
SH: 11.1 UAH	QH: 5.2 VARH
HZ: 50.0 Hz	MD: UA MD: W -15
3φ3W	SEC: 2 CT: 1 UT: 1

For the meaning of each parameter, refer to XIV. Nomenclature.

III.3. Power Quality of a Single Phase (1P2W) System

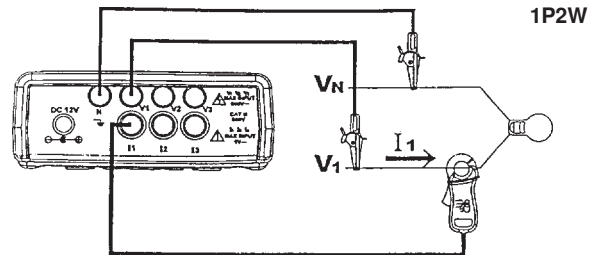

- Turn the power on. Press the POWER and the 1φ2W buttons to select the 1P2W system. The type of system will be displayed at the bottom right of the LCD.
- Connect the four test leads to the voltage terminals L1 and VN (Neutral) of the system.
- Connect one current probe to the power analyzer input terminal I1.
- Clamp on to the L1. Make sure the current flow from the front of the current probe to the back of it.
- All parameters of the system will be shown in LCD

U1: 219.9 V	I1: 797.9 mA
PΣ: 156.3 W	SΣ: 175.3 VA
QΣ: -79.5 VAR	PFΣ: 0.89
PFH: 0.89	φ1: -27.1°
WH: 8.0 WH	SH: 9.0 UAH
QH: 4.1 VARH	HZ: 50.0 Hz
MD: UA MD: W -15	1φ2W
SEC: 2	CT: 1
UT: 1	

For the meaning of each parameter, refer to XIV. Nomenclature.

III.4 Power Quality of a 1 Phase 3 Wire (1P3W) System

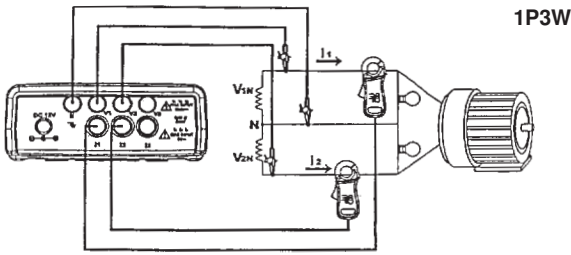

- Turn the power on. Press the POWER and the 1φ3φ buttons to select the 1P3W system. The type of system will be displayed at the bottom right of the LCD.
- Connect the four test leads to the voltage terminals L1, L2 and the V_N (Neutral) of the system.
- Connect the two current probe to the power analyzer input terminal I1 and I2.
- Clamp on to the L1 and L2. Make sure the current flow from the front of the current probe to the back of it.
- All parameters of the system will be shown in LCD.

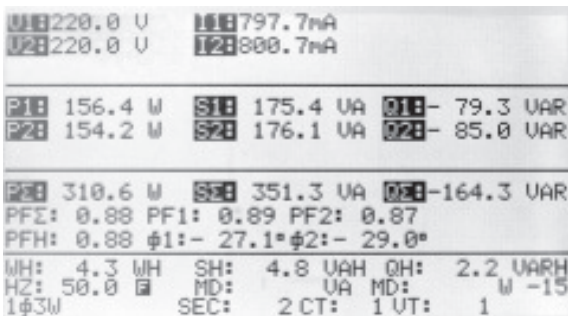

For the meaning of each parameter, refer to XIV. Nomenclature.

III.5 Measurement of a System with CT or VT

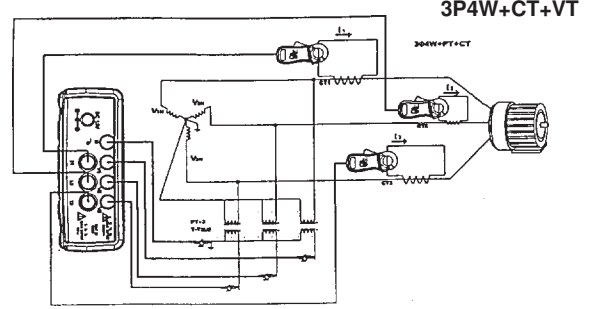

- Turn the power on. Press the POWER and the 1φ3φ buttons to select the 3P4W system. The type of system will be displayed at the bottom right of the LCD.
- Connect the four test leads to the secondary voltage terminals L1, L2, L3 and the V_N (Neutral) of the system.
- Clamp on to the secondary coils of L1, L2, and L3. Make sure the current flow from the front of the current probe to the back of it.
- Press the SETUP button several times until the CT symbol is shown in reverse video in LCD.
- Press the ▲ or ▼ button to increment or decrement the RATIO specified by the CT.

III.6 Harmonic Analysis of Voltage or Current

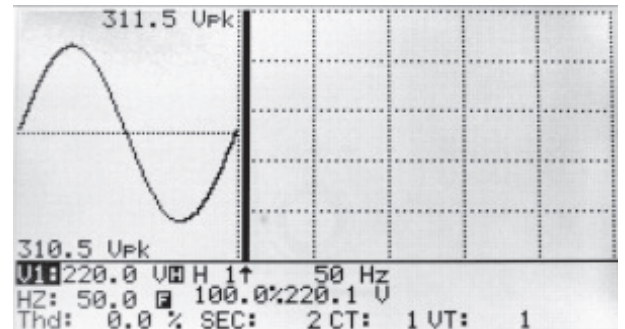

(Normal Voltage without Distortion and Harmonics)

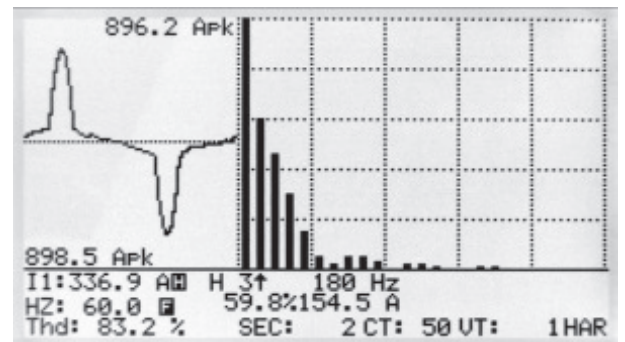

(Distortion Current with Harmonics)

- Setup the analyzer for measurement of any power system (3P4W, 3P3W, 1P2W or 1P3W). To see the harmonic analysis of voltage or current, users can press the MAG button.

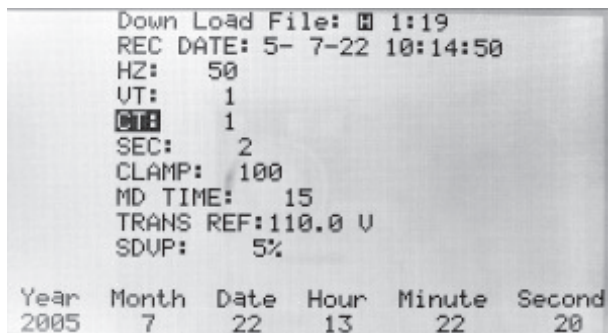

- Press the SETUP button several times until the VT symbol is shown in reverse video in LCD.
- Press the ▲ or ▼ button to increment or decrement the RATIO specified by the VT.

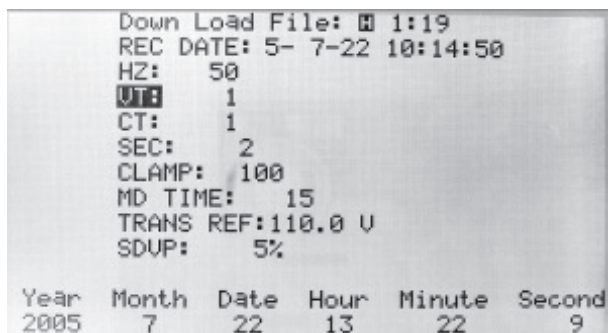

- Press EXIT to return to POWER mode. All the parameters of the system will be shown in LCD.

For the meaning of each parameter, refer to XIV. Nomenclature.

- b. Once the MAG button is pressed, the waveform will be shown in the left part in LCD and the 1ST to 50th order harmonic will be shown in the right part in LCD.
- c. The positive and negative peak values will be shown in the waveform (Vpk).
- d. The TRMS value and total harmonic distortion (THD-F) of voltage or current will be shown under the waveform.
- e. The cursor (arrow) will point to the current order of harmonic. The frequency (HZ) will be displayed next to the cursor. The percentage of Harmonic (%) will be displayed below the cursor. The magnitude of the harmonic (V or A) or Phase angle will be displayed next to the %.
- f. To move the cursor to next harmonic, press the ◀ or ▶ button.
- g. To see the next page of 51ST to 99th order, press the ▶ button to pass 50th order or press the ◀ button to pass 1ST order.

NOTE : If the waveform is chopped off at the peak or too small in the LCD, press the RANGE button to select HIGH or LOW range for better display. The range indicator is a symbol after the unit of RMS value, L or H.

III.7 Display the Phase Angle of harmonics

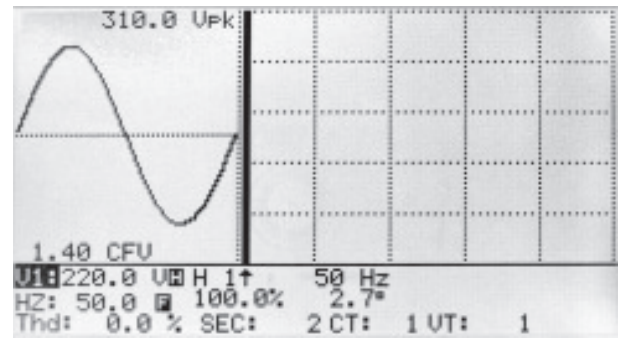

When the MAG is pressed the magnitude of each harmonics is displayed. To review the phase angle of each harmonics, user can press the PHASE button. The phase angle shall be displayed next to the %. This phase angle is measured from the sampled waveform. It may not 0 for V1. The rest of the phase angle (V2, V3, I1, I2 and I3) is sampled with respect to V1.

NOTE : If the waveform is chopped off at the peak or too small in the LCD, press the RANGE button to select HIGH or LOW range for better display, The range indicator is symbol after the unit of RMS value, L or H.

III.8 Measurement of Maximum Demand

1. Setup the time interval for maximum demand (refer to section VII)
2. The analyzer will integrate the KW and KVA over the specified interval.
3. The maximum demand (MD) will be updated if new demand is greater than the previous value.

In the following example, the maximum demand is 527.4VA and 527.4W. The time interval for maximum demand is 2 minutes.

U1: 381.8 U	U2: 220.0 U	I1: 798.5 mA
U2: 380.8 U	U2: 220.0 U	I2: 800.7 mA
U3: 379.7 U	U3: 219.6 U	I3: 801.7 mA
P1: 175.4 W	S1: 175.6 VA	Q1: 8.3 VAR
P2: 176.1 W	S2: 176.1 VA	Q2: 0.0 VAR
P3: 176.0 W	S3: 176.0 VA	Q3: 0.0 VAR
PΣ: 527.5 W	SΣ: 527.5 VA	QΣ: 8.3 VAR
PFΣ: 1.00	PF1: 0.99	PF2: 1.00
PF3: 1.00	PFH: 0.98	φ1: 2.9°
	φ2: 1.0°	φ3: 0.8°
WH: 60.7 WH	SH: 61.9 UAH	QH: 3.9 UARH
HZ: 50.0	MD: 527.4 UA	MD: 527.4 W - 2
3φ4U	SEC: 2	CT: 1 UT: 1

III.9 Waveform of Voltage and Current

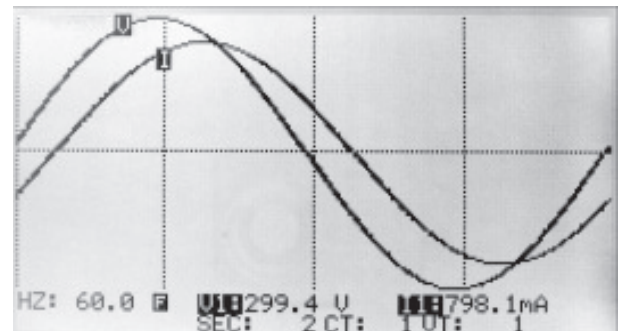

Press the  button to display to waveform of voltage and current at the same time.

To select different input (V1,I1), (V2,I2) or (V3,I3) press the button. 

NOTE : The triggering point is the zero crossing point of V1 for V2,V3,I2 and I3. The triggering point for I1 is its own zero crossing point in case V1 is not present.

NOTE : In the mode of displaying waveform, one period/cycle of 1024 data is displayed.

III.10 Waveform of Voltage only

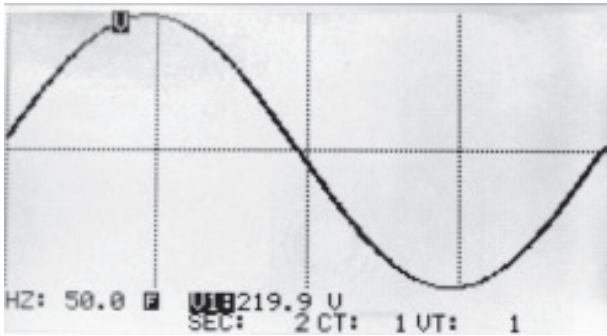

Press the button to display voltage waveform only. The true RMS value of voltage will be displayed at the bottom in LCD.



Press the button to select V1, V2 or V3.

NOTE : The triggering point is the zero crossing point of V1 for V2,V3.

NOTE : In the mode of displaying waveform, one period/cycle of 1024 data is displayed.

III.11 Graphic Phasor Diagram

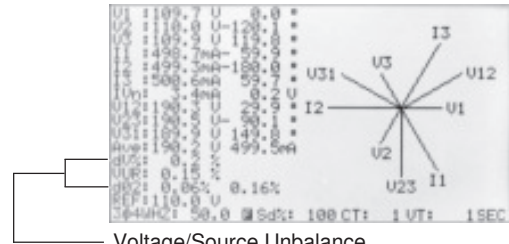

Press the button to display the phasor diagram.

The voltages and currents will be displayed in phasor format (magnitude, angle). V1 will be referred as reference.

The angle of V1 is always 0, The phase angles of V2, V3, I1, I2, and I3 will be displayed with respect to V1. V1, V2, V3, I1, I2, I3, V12, V23 and V31 will be displayed in vector form graphically.

V1, V2, V3 : Phase voltages in phasor format with respect to V1.

I1, I2, I3 : Line currents in phasor format with respect to V1.

I_n : Calculated voltage and current of neutral with respect to ground.

V12, V23, V31 : Line voltage in phasor format with respect to V1.

Ave : Average of line voltages V12, V23, and V31 and line current I1, I2 and I3

dV% : Historical maximum % value of

$(\text{Max}(V1, V2, V3) - \text{Min}(V1, V2, V3)) / \text{Min}(V1, V2, V3) * 100\%$

VUR : Voltage Unbalance Ratio

d02 : The first number is Zero Sequence Unbalance Ratio in % (d0) of voltage. The second number is the Negative Sequence Unbalance Ratio in % (d2) of voltage.

When VUR is displayed before d02, d02 represent the Zero and Negative Sequence Unbalance Ratios for voltage.

REF : nominal voltage for transient detection reference

Sd% : threshold in % for transient detection with respect to nominal voltage (REF).

NOTE : The phasor is drawn only when the reading is more than 200 counts. And if the reading of V is zero, then phasor of current will not be drawn.

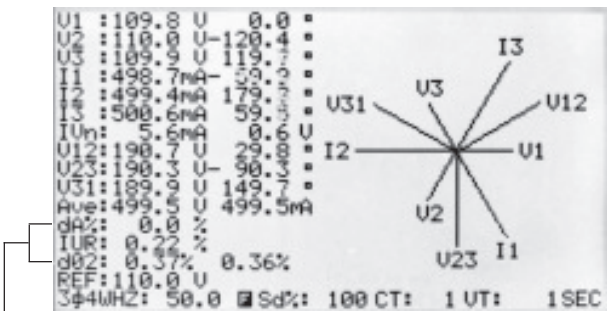

Current/Load Unbalance



To change the display of VUR to IUR, press the button

dA% : Historical maximum % value of

$(\text{Max}(I1, I2, I3) - \text{Min}(I1, I2, I3)) / \text{Min}(I1, I2, I3) * 100\%$

IUR : Current Unbalance Ratio

d02 : The first number is Zero Sequence Unbalance Ratio in % (d0) of current, the second number is the Negative Sequence Unbalance Ratio in % (d2) of current. When IUR is displayed before d02, d02 represent the Zero (d0) and Negative (d2) Sequence Unbalance Ratios for current.

REF : nominal voltage for transient detection reference

Sd% : threshold in% for transient detection with respect to nominal voltage (REF).

NOTE : If the voltage of L1,L2 and L3 is not connected in right sequence, the analyzer will show L1-3-2 in the right top corner, and beep to warn the users of incorrect phase sequence.

III.12 Phase Sequence of a 3 Phase System

Incorrect Sequence

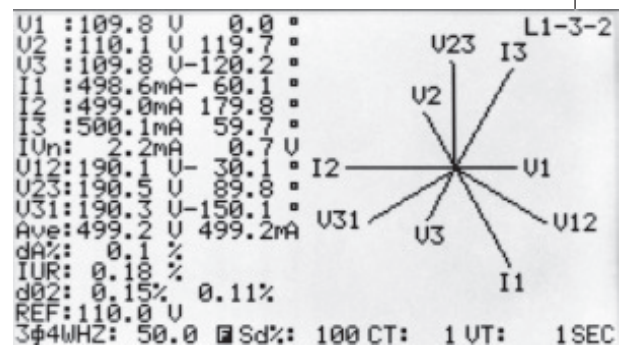

Users can press the button to enter the mode of phase or diagram.

In this mode, the analyzer also detects the correctness of the phase sequence. If the voltage of L1, L2, and L3 is not connected in right sequence, the analyzer will show L1-3-2 in the right top corner and beep to warn the users of incorrect phase sequence.

III.13 Balance and Unbalance 3 Phase (3P3W, 3P4W) Power Source System

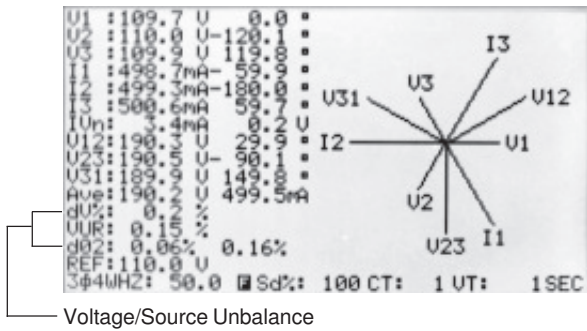

In order to check if a system is balanced,  press the button to display the phasor diagram with the VUR displayed.

Balance System

If a 3 phase power source system is balance, the parameters should be as following :

$$V1 = V2 = V3$$

$$V12 = V23 = V31$$

The phase angle of phasor V2 = -120

The phase angle of phasor V3 = 120

Vn (voltage of neutral with respect to ground) = 0V

VUR = 0%

d0% = 0%

d2% = 0%

Unbalance System

If the values are different from the numbers above, then we can say it is an unbalance power source system. The magnitude of the difference can be used as an indication of an unbalance power source system. The larger the difference, the more unbalance the system is.

III.14 Balance and Unbalance 3 Phase (3P3W or 3P4W) Load System

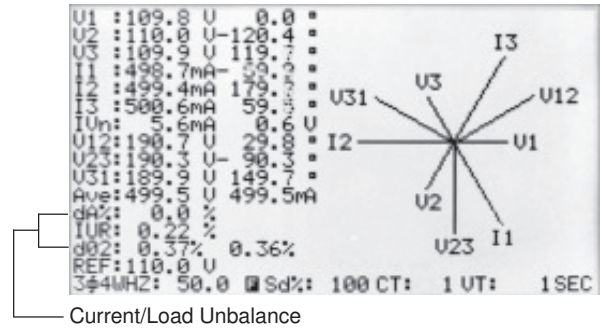

In order to check if a system is balance,  press the button twice to display the phasor diagram with the IUR displayed.

Balance System

If a 3 phase load system is balance, the parameters should be as following :

$$I1 = I2 = I3$$

The phase angle of phasors I2 and I1 ($I2 \pm I1$) = ± 120

The phase angle of phasors I3 and I2 ($I3 \pm I2$) = ± 120

In (current of neutral) = 0A

IUR = 0%

d0% = 0%

d2% = 0%

Unbalance System

If the values are different from the numbers above, then we can say it is an unbalance load system. The magnitude of the difference can be used as an indication of an unbalance power source system. The larger the difference, the more unbalance the load is.

III. 15 Transient Capture (Dips, Swells, Outage)

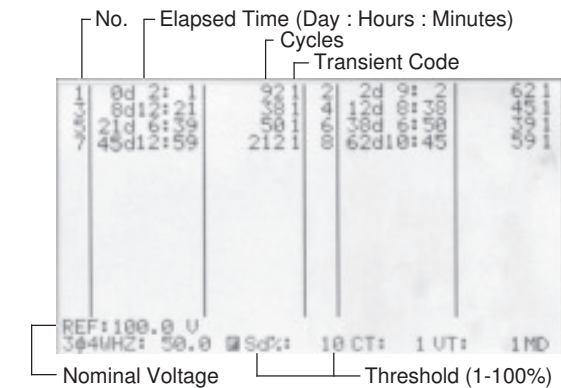

1. Press button  to enter the mode of PHASOR DIAGRAM.
2. Press the SETUP button to let TRANS REF is displayed in reverse video.



3. Press the ▲ or ▼ button of increment or decrement nominal voltage as reference. To exit, press the EXIT button.
4. Press the SETUP button to let SDVP displayed in reverse video.

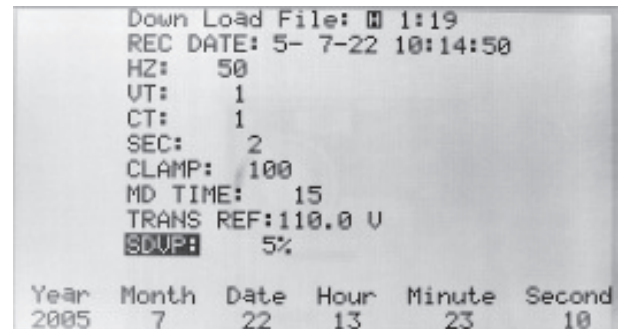

5. Press the ▲ or ▼ button to increment or decrement threshold in % (SDVP). To exit, press the Exit button.
6. Press the TRANSIENT button to start operation of "Transient Capture".
7. The backlight will be turned off when the TRANSIENT button is pressed.
8. If the analyzer captures any transient events (DIP, SWELL or OUTAGE) the backlight will be turned on. User can press the TRANSIENT button to review the TRANSIENT events recorded.
9. To exit TRANSIENT CAPTURE press the EXIT button.

Definition of SWELL, DIP and OUTAGE :

SWELL : $V_{RMS} > [V_{REF} + (V_{REF} * SD\%)]$

Code for SWELL : 1

If the true RMS value of either phase (V1, V2, or V3) rises above the nominal value plus the threshold (REF + SD%), it is regarded as SWELL. The code for SWELL is 1.

DIP : $V_{RMS} < [V_{REF} - (V_{REF} * SD\%)]$

Code for DIP : 2

If the true RMS value of either phase (V1, V2, or V3) falls below the nominal value plus the threshold, it is regarded as DIP. The code for DIP is 2.

OUTAGE : $V_{RMS} < 30 \text{ to } 40V$

Code for OUTAGE : 4

If the true RMS value of either phase is less than 30 to 40V, it is regarded as OUTAGE. The code for OUTAGE is 4.

Code Table :

	SWELL	DIP	OUTAGE	COMMENT
CODE	1	2	4	Codes can be added together

DISPLAY FORMAT :

First column : sequential number of events.

Second column : elapsed time since the time of start. The elapsed time format is (DAYS, HOURS, MINUTES).

The maximum time is 99 day 24 hours 60 minutes.

The third column : number of cycles.

The fourth column : code of transient events.

There might be more than one transient condition occurs in one event.

NOTE : In the made of TRANSIENT CAPTURE the analyzer takes 128 samples each cycle for each phase continuously.

NOTE : When the users press the TRANSIENT button to review the recorded events, the analyzer stops capture operation until the TRANSIENT is pressed again. The timer is also stopped when

users press the TRANSIENT button. So the time stamp is not correct when users press the TRANSIENT button to resume operation.

NOTE : The analyzer can record up to 28 events. When the analyzer has recorded 28 events, it stops the capture operation, turns the backlight on, and displays the 28 transient events.

NOTE : The code can be added together to indicate two or three conditions. For example, if cods is 6, that means DIP and OUTAGE (2+4).

NOTE : The longest duration for capture operation is 99 days. So users should use external 12V DC power adaptor for capture operation.

WARNING : Users must select 50 or 60 Hz for transient capture. If users select AUTO for frequency, the unit will not allow users to enter the TRANSIENT capture, and will beep to warn users.

III.16 Down Load Transient Data

When users press the TRANSIENT button to display CAPTURED EVENTS, the data is also output through RS-232 at the same time.

The data output is in the same format as in LCD in ASCII format
YEAR MONTH DAY HOUR MINUTE SECOND CT REF CODE

01 ELAPSED_TIME CYCLES CODE

02 ELAPSED_TIME CYCLES CODE

03 ELAPSED_TIME CYCLES CODE

04 ELAPSED_TIME CYCLES CODE

NOTE : When users download data in the office, one additional event will be captured due to no input connected. The additional (last) event should show:

1. Elapsed time is reset to 0.
2. Transient event is LO and OUT.

III.17 Data Logging of Power Data (3P4W, 3P3W, 1P2W,1P3W)

1. Set the sampling time of data logging
2. Press the POWER button to enter mode af power measurement.
3. Press the 1φ3φ button to select appropriate system (3P4W, 3P3W, 1P3W or 1P2W).
4. Press the REC button to start data logging. A REC symbol will displayed at the bottom line in LCD.
If the memory is full, a FULL symbol will display at the bottom line in LCD, and the buzzer will last 3 seconds. Now the recording function is disabled, i.e. pressing the REC button won't work.
5. To stop data logging, press the REC button again.

WARNING : It there is no input at V1, then ths timing of sampling could be longer than the set value.

III.18 Down Load Power Data

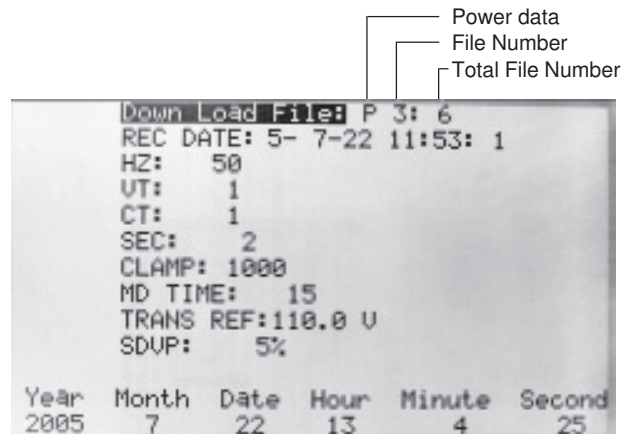

1. Press the SETUP button.
2. The "Down Load File" will be shown in reverse video.
3. Press the ▲ or ▼ button select file number.
4. If the data stored in a selected file is power data, a leading symbol "P" will be shown in front of the file number.
5. Press EXIT button.
6. When the unit recieve a CTRL+D command through the RS-232C port, it will download stored power data.

NOTE : In the setup mode, the unit will not accept any command through RS-232C port. To download data, users must press the EXIT button to return to normal measurement mode.

III.19 Data Logging of Harmonics

1. Set the sampling time of data logging.
2. Press MAG. button to enter mode of harmonics measurement.
3. Press the VI button to select desired input (V1, I1, V2, I2, V3 or I3).
4. Press the REC button to start data logging. A REC symbol will be displayed at the bottom line in LCD.
If the memory is full, a FULL symbol will display at the bottom line in LCD, and the buzzer will last 3 seconds. Now the recording function is disabled, i.e. pressing the REC button won't work.
5. To stop data logging, press the REC button again.

WARNING : If there is no input at V1, then the logging time will be incorrect.

III.20 Down Load Harmonics Data

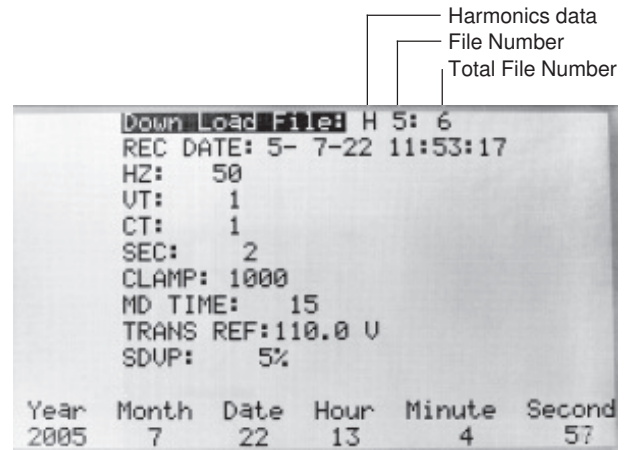

1. Press the SETUP button.
2. The "Down Load File" will be shown in reverse video.
3. Press the ▲ or ▼ button select file number.
4. If the data stored in a selected file is harmonics data, a leading symbol "H" will be shown in front of the file number.
5. Press EXIT button.
6. When the unit receive a CTRL+D command through the RS-232C port, it will download stored harmonics data.

NOTE : In the setup mode, the unit will not accept any command through RS-232C port. To download data, users must press the EXIT button to return to normal measurement mode.

IV. HARDCOPY OF SCREEN

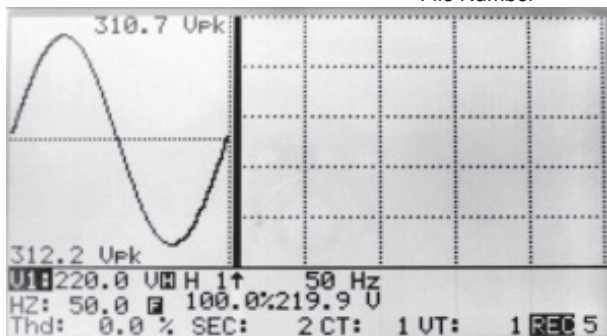

1. Press the HOLD/READ button.
2. Press the REC button. It takes few seconds to hardcopy the screen, and store the screen in an internal file. The LCD will show REC in reverse video when in operation. The number following the REC is the file number.
3. Users can store up to 85 screens if no power or harmonics data is stored.

V. READ THE SAVED SCREEN

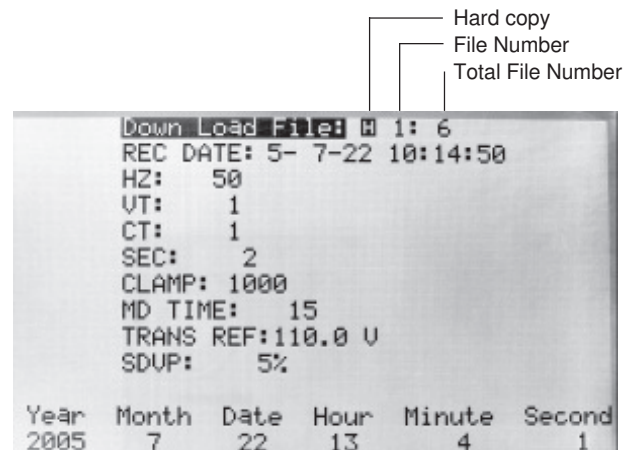

1. Press the SETUP button. The DOWNLOAD FILE is displayed in reverse video. If the data selected file is hardcopy of screen, a leading symbol "H" will be shown in displayed in reverse video.
2. Press the ▲ or ▼ to select the saved screen.
3. Press the HOLD/READ button, then the saved screen will be restored.

NOTE : If the data saved in a specific file is HARDCOPY of screen, a leading symbol "H" is displayed in reverse video.

NOTE : Hardcopy data can not be down loaded.

VI. SET THE CT AND VT RATIO

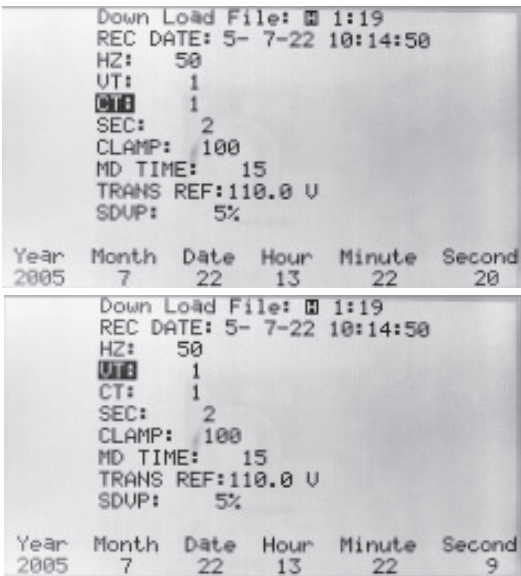

To set the CT or VT ratio, press the SETUP button several times until CT or VT is shown at the right bottom corner in LCD. Users can press the ▲ or ▼ button to increment or decrement the value by 1. Holding the ▲ or ▼ button will speed up the process of incrementing or decrementing. To exit, press the EXIT button. The range of CT ratio is from 1 to 600. The range of VT ratio is from 1 to 3000. Once the CT or VT is set, the voltage and current readings becomes
 CURRENT (displayed) = CURRENT (measured) x CT Ratio
 VOLTAGE (displayed) = VOLTAGE (measured) x VT Ratio

VII. SET THE TIME INTERVAL FOR MAXIMUM DEMAND

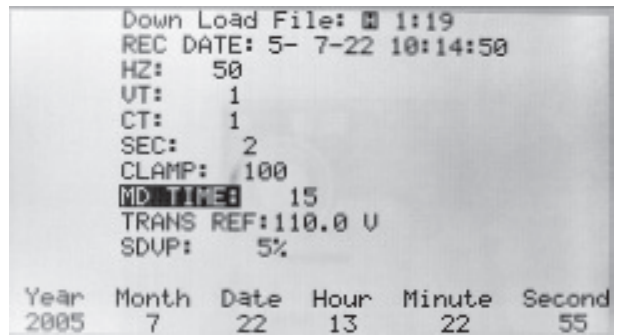

To set the time interval in minutes, press the SETUP button several times until MD is shown at the right bottom corner in LCD. Users can press the ▲ or ▼ button to increment or decrement the value by 1. Holding the ▲ or ▼ button will speed up the process of incrementing or decrementing. To exit, press the EXIT button. The range of MD time interval is from 1 to 60 minutes. Once the time interval is set, the unit will calculate the maximum demand and average demand in wattage (W) or VA. To toggle between W and VA, press the POWER button.

VI. SET THE SAMPLING TIME FOR DATA LOGGING

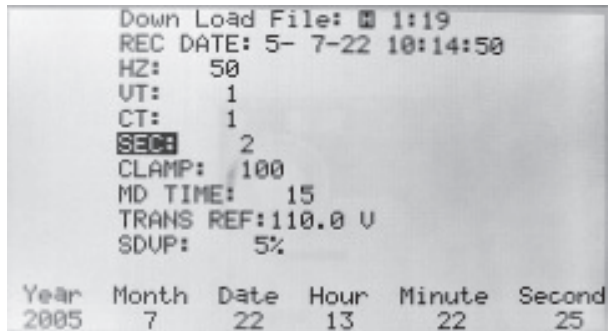

To set the sampling time for data logging in minutes, press the SETUP button several times until SEC is shown at the right bottom corner in LCD. Users can press the ▲ or ▼ button to increment or decrement the value by 2. Holding the ▲ or ▼ button will speed up the process of incrementing or decrementing. To exit, press the EXIT button.

IX. SET THE CALENDER CLOCK

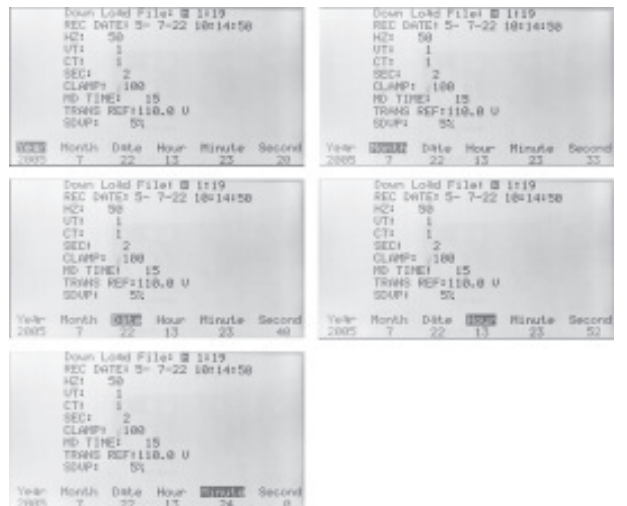

1. Press the SETUP button to select (Year, Month, Date, Hour, Minute).
 2. Press the ▲ or ▼ button to increment or decrement the number.
- NOTE :** Second can't be adjusted.

X. PROTOCOL OF RS-232C INTERFACE

RS-232C Interface :
 Baud Rate 19200
 Data bits 8
 Stop bit 1
 No Parity

XI. SPECIFICATIONS (23°C ± 5°C)

AC Watt

(50 or 60 Hz, PF 0.5 to 1, CT = 1, Voltage > AC 20V, Current > AC 40mA for 1A range, Current > AC 0.4A for 10A range, Current > AC 4A for 100A range and continuous waveform)

Model PHA5850A (100A)

Range (0 to 100A)	Resolution	Accuracy of Readings ¹
5.0 - 999.9 W	0.1W	±1% ± 0.8W
1.000 - 9.999 KW	0.001 KW	±1% ± 8W
10.00 - 99.99 KW	0.01 KW	±1% ± 80W
100.0 - 999.9 KW	0.1 KW	±1% ± 0.8KW
1000 - 9999 KW	1 KW	±1% ± 8KW

(50 or 60 Hz, PF 0.5 to 1, CT = 1, Voltage > AC 20V, Current > AC 4A for 100A range, and Current > AC 40A for 1000A range, and continuous waveform)

Model PHA5850B (1000A)

Range (0 to 1000A)	Resolution	Accuracy of Readings ²
5.0 - 999.9 W	0.1W	±1% ± 0.8W
1.000 - 9.999 KW	0.001KW	±1% ± 8W
10.00 - 99.99 KW	0.01KW	±1% ± 80W
100.0 - 999.9 KW	0.1KW	±1% ± 0.8KW
1000 - 9999 KW	1KW	±1% ± 8KW
0.000 - 9.999 MW	0.001MW	±1% ± 80KW

(50 or 60 Hz, PF 0.5 to 1, CT = 1, Voltage > AC 5V, Current > AC 5A for A range, and continuous waveform. Conductor is located at the center of flexible loop. Position sensitivity is 2% of range. External field effect of <40A/m and 200mm from the coupling is 1% of range. Temperature coefficient is 0.02% of reading / °C)

Model PHA5850C (3000A)

Range (0 to 3000A)	Resolution	Accuracy of Readings ³	
		>20V and >30A	<20V and <30A
10.0 - 999.9 W	0.1W	±1% of range	±2% of range
1.000 - 9.999 KW	0.001 KW	±1% of range	±2% of range
10.00 - 99.99 KW	0.01 KW	±1% of range	±2% of range
100.0 - 999.9 KW	0.1 KW	±1% of range	±2% of range
1000 - 9999 KW	1 KW	±1% of range	±2% of range

^{1,2,3} For CT≠1, accuracy in percentage is the same (±1%) But the additional digits should be multiplied by the CT ratio.

For example, ±0.8W becomes ±0.8W *CT ratio

Range of CT (Current Transformer) Ratio : 1 to 600

AC Apparent Power (VA from 0.000VA to 9999 KVA)

$$VA = V_{r.m.s.} \times A_{r.m.s.}$$

AC Reactive Power (VAR from 0.000VAR to 9999 KVAR)

$$VAR = N(\sqrt{VA^2 - W^2})$$

AC Active Energy (mWH, WH or KWH from 0 mWH to 999.999 KWH)

$$WH = W \times \text{Time (in hours)}$$

AC Current

(50 or 60 Hz, Auto Range, True RMS, Crest Factor < 4, CT = 1)

Model PHA5850A (Overload Protection AC 200A)

Range	Resolution	Accuracy of Readings ⁴
0.04 - 1A	0.001A	±0.5% ± 0.05A
0.4A - 10A	0.01A	±0.5% ± 0.05A
4 - 100A	0.1A	±1.0% ± 0.5A

Model PHA5850B (Overload Protection AC 2000A)

Range	Resolution	Accuracy of Readings ⁵
10.00A	0.001A/0.01A	-
4A-100.0A	0.01A/0.1A	±0.5% ± 0.5A
40A-1000.0A	0.1A/1A	±0.5A% ± 5A

Model PHA5850C (Overload Protection AC 3000A)

Range	Resolution	Accuracy of Readings ⁶
0-300.0A	0.1A	±1% of range
300.0-3000A	0.1A/1A	±1% of range

^{4,5,6} For CT ≠ 1, accuracy in percentage is the same (±0.5%) But the additional digits should be multiplied by the CT ratio.

For example, ±0.5A becomes ± 0.5A * CT ratio

AC Voltage

(50 or 60 Hz, Auto Range, True RMS, Crest Factor < 4, Input Impedance 10 MΩ, VT (PT)=1, Overload Protection AC 800V)

Range	Resolution	Accuracy of Readings ⁷
20.0V - 500.0 V (Phase to Neutral)	0.1V	±0.5% ± 5dgts
20.0V - 600.0 V (Phase to Phase)		±0.5% ± 5dgts

⁷For VT (PT) ≠ 1, accuracy in percentage is the same (±0.5%). But the additional digits should be multiplied by the CT ratio.

For example, ±5digits becomes ±5digits * VT (PT) ratio

Harmonic of AC Voltage in Percentage

(1 to 99th order, minimum voltage at the 50 or 60 Hz > AC 80 V. If the voltage is 0 at 50 or 60 Hz, all the percentage (%) display is 0.)

Range	Resolution	Accuracy
1 - 20th	0.1%	±2%
21 - 49th		±4% of reading ±2.0%
50 - 99th		±6% of reading ±2.0%

Hamonics of AC Voltage in Magnitude

(1 to 99th order, minimum voltage at the 50 or 60 Hz > AC 80V, VT = 1)

Range	Resolution	Accuracy
1 - 20th	0.1V	±2% ±0.5%
21 - 49th		±4% of reading ±0.5V
50 - 99th		±6% of reading ±0.5V

Harmonic of AC Current in Percentage

(1 to 99th order, minimum current at the 50 or 60 Hz is Model 5850A >10% of the range Model 5850B > 20A Model 5850C > 30A. If the current is 0 at 50 or 60 Hz, all the percentage (%) display is 0.)

Model PHA5850A

Range	Resolution	Accuracy
1 - 10th	0.1%	±0.2% of reading ±1%
11 - 20th		±2% of reading ±1%
21 - 50th (A range)		±5% of reading ±1%
21 - 50th (mA range)		±10 of reading ±1%
51 - 99th		±35% of reading ±1%

Model PHA5850B

Range	Resolution	Accuracy
1 - 20th	0.1%	±2%
21 - 49th		±4% of reading ±2.0%
50 - 99th		±6% of reading ±2.0%

Model PHA5850C

Range	Resolution	Accuracy
1 - 20th	0.1%	±2%
21 - 49th		±6%
51 - 99th		±10%

Hamonics of AC Current in Magnitude

(1 to 99th order, min.current at the 50 or 60 Hz Model 5850A > 10% of the range Model 5850B > 20A, CT = 1)

Model PHA5850A

Range	Resolution	Accuracy
1 - 10th	0.1mA/0.1A	±0.2% of reading ±1%
11 - 20th		±2% of reading ±1%
21 - 50th (A range)		±5% of reading ±1%
21 - 50th (mA range)		±10% of reading ±1%
51 - 99th		±35% of reading ±1%

Model PHA5850B

Range	Resolution	Accuracy
1 - 20th	0.1A	±2% of reading ±0.4A
21 - 49th		±4% of reading ±0.4A
50 - 99th		±6% of reading ±0.4A

(1 to 99th order min. current at the 50 to 60Hz, True RMS < 300A)

Model PHA5850C

Range (0-300A)	Resolution	Accuracy
1 - 20th	0.1%	±2% of reading ±4A
21 - 50th		±4% of reading ±4A
51 - 99th		±6% of reading ±4A

(1 to 99th order min. current at the 50 to 60Hz, 3000A > True RMS > 300A)

Model PHA5850C

Range (300-3000A)	Resolution	Accuracy
1 - 20th	0.1%	±2% of reading ±4A
21 - 50th		±4% of reading ±4A
51 - 99th		±6% of reading ±4A

Power Factor (PF)

Model PHA5850A & PHA5850B

Range	Resolution	Accuracy
0.00 - 1.00	0.01	±0.04

Model PHA5850C

Range	Resolution	Accuracy of Readings ³	
		>20V and >30A	<20V and <30A
0.000 - 1.000	0.001	±0.04	±0.1

Phase Angle (F)

Model PHA5850A & PHA5850B

Range	Resolution	Accuracy
-180° to 180°	0.1°	±1°

Model PHA5850C (FV>20V, A>30A)

Range	Resolution	Accuracy
-180° to 180°	0.1°	±2°
0° to 360°	0.1°	±2°

Peak Value of AC Voltage

(peak value > 20V) or ACA (peak value Model 5850A 10% of the range Model 5850B > 20A Model 5850C > 30A) VT=1

Range	Sampling Time	Accuracy of Reading
50 Hz	19ms	±5% ± 30 digits
60 Hz	16ms	±5% ± 30 digits

Crest Factor (CF) AC Voltage

(peak value > 20V) or ACA (peak value Model 5850A 10% of the range Model 5850B > 20A Model 5850C > 30A) VT=1

Range	Resolution	Accuracy of Reading
1.00 - 99.99	0.01	±5% ±30 digits

Frequency in AUTO mode

Model PHA5850A & PHA5850B

Range	Resolution	Accuracy of Reading
45 - 65 Hz	0.1 Hz	0.1 Hz

Frequency

of ACV (RMS value > 10V) or ACA (RMS value > 30A)

Model PHA5850C

Range	Resolution	Accuracy of Reading
45 - 65 Hz	0.1 Hz	0.2 Hz

Total Harmonic Distortion

(THD-F with respect to the fundamental frequency. min. value at the 50 or 60 Hz is voltage > AC 80V and current is model 5850A > 10% of the range Model 5850B > 20A Model 5850C > 30A. Calculation is done over 1 to 50th Harmonics. If the voltage or current is 0 at 50 or 60 Hz, all the percentage (%) display is 0.)

Model PHA5850A

Range	Resolution	Accuracy
0.0 - 20.0%	0.1%	±1%
20.0 - 100%		±3% of reading ±5%
100 - 999.9%		±10% of reading ±10%

Model PHA5850B

Range	Resolution	Accuracy
0.0 - 20%	0.1%	±2%
20 - 100%		±6% of reading ±1%
100 - 999.9%		±10% of reading ±1%

Model PHA5850C

Range	Resolution	Accuracy
0.0 - 20%	0.1%	±2%
20 - 100%		±6% of reading ±5%
100 - 999.9%		±10% of reading ±10%

GENERAL SPECIFICATION

Model PHA5850 Analyser

- Battery Type : 1.5V SUM-3 x 8
- External DC Input : Power supply adapter 12V DC
- Display : Dot Matrix LCD (240x128) with backlight
- LCD Update Rate : 1 time/second
- Waveform capture time : 20micro sec. (50Hz)
16micro sec. (60Hz)
- Power Consumption : 140mA (approx.)
- No. of Samples : 1024 samples / period
- Data Logging Files : 85
- Max. File Capacity : 17474 records (3P4W, 3P3W)
26210 records (1 P3W)
52420 records (1P2W)
4096 records (50 Hamonics / record)
- Sampling Time : 2 to 3000 seconds for data logging
- Low battery Indication : **B**
- Overload Indication : OL
- Operating Temperature : -10°C to 50°C
- Operating Humidity : less than 85% relative
- Storage Temperature : -20°C to 60°C
- Storage Humidity : less than 75% relative
- Dimension : 257(L) x 155(W) x 57(H) mm
10.1"(L) x 6.1"(W) x 2.3"(H)
- Weight : 1160g (Batteries included)
- Accessories : Voltage Test leads for voltage x 4
Current Probes (A or B or C) x 3
Voltage Alligator clips x 4
Carrying bag x 1
Users manual x 1

Batteries 1.5V x 8
 Software CD x 1
 Software users manual x 1
 USB to RS232 cable x 1

Model PHA5850A Current Probe (1/10/100A)

Conductor Size : 30mm (approx.)
 Range Selection : Manual (1A, 10A, 100A)
 Dimension : 210mm (L) x 62mm (W) x 36mm (H)
 8.3" (L) x 2.5" (W) x 1.4" (H)
 Weight : 200g

Model PHA5850B Current Probe (10/100/1000A)

Conductor Size : 55mm (approx.) 64 x 24mm (bus bar)
 Range Selection : Manual (10A, 100A, 1000A)
 Dimension : 244mm (L) x 97mm (W) x 46mm (H)
 9.6" (L) x 3.8" (W) x 1.8" (H)
 Weight : 600g

Model PHA5850C Flexible Current Probe (300/3000A)

Probe Length: 3007-24 : 24 in / 610 mm
 Minimum Bending : 35mm
 Diameter
 Connector Diameter : 23mm
 Cable Diameter : 14mm
 Cable Length from : 170mm
 Probe to Box
 Cable Length from : 170mm
 Box to Output
 Range Selection : Manual (300A, 3000A)
 Battery : powered by power analyzer
 Dimension (Box) : 130mm(L) x 80mm(W) x 43mm(H)
 5.1"(L) x 3.1"(W) x 1.7"(H)
 Weight : 410g

XII. BATTERY REPLACEMENT

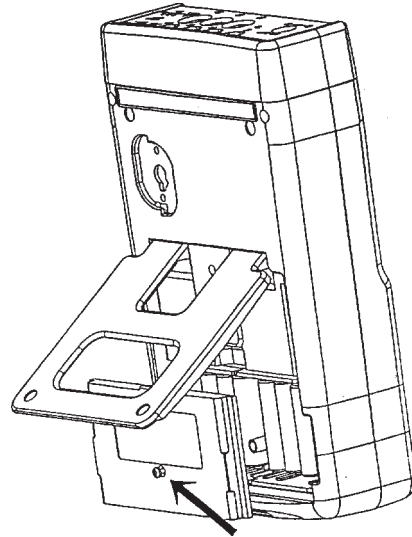

When the low battery symbol is displayed on the LCD, replace the old batteries with eight new batteries.

- A. Turn the power off and remove all the test leads and current probes from the unit.
- B. Remove the screw of the battery cover.
- C. Lift and remove the battery cover.
- D. Remove the old batteries.
- E. Insert eight new 1.5V SUM-3 batteries.
- F. Replace the battery cover and secure the screw.

XIII. MAINTENANCE & CLEANING

Servicing not covered in this manual should only be performed by qualified personnel. Repairs should only be performed by qualified personnel. Periodically wipe the case with a damp cloth and detergent; do not use abrasives or solvents.

For Flexible probes

Always inspect the flexible current probe for any damage. If users find any damage, don't use the flexible current probe. Return the probe to a qualified person for repair or replacement.

XIV. NOMENCLATURE

- V12, V23, V31: Line Voltage
- V1, V2, V3: Phase Voltage
- I1, I2, I3: Line Current
- P1, P2, P3: True Power (W) of Each Phase
- S1, S2, S3: Apparent (VA) Power of Each Phase
- Q1, Q2, Q3: Reactive Power (VAR) of Each Phase
- P_{Σ} : Total System Power (W)
- S_{Σ} : Total System Apparent Power (VA)
- Q_{Σ} : Total Reactive Power (VAR)
- PF_{Σ} : Total System Power Factor (PF)
- PF1, PF2, PF3: Power Factor of Each Phase
- PFH: Long Term Average Power Factor (WH / SH)
- $\phi 1, \phi 2, \phi 3$: Phase Angle of Each Phase
- WH: Watt Hours
- SH: VA hours
- QH: VAR hours
- HZ: Selected Frequency 50, 60 or Auto.
- MD: Maximum Demand in W and VA over Specified Interval
- 3P4W: 3 Phase 4 Wire System
- 3P3W: 3 Phase 3 Wire System
- 1P2W: Single Phase 2 Wire System
- 1P3W: Single Phase 3 Wire System
- SEC: sampling interval in seconds from 2 to 3000 for data logging
- CT: Current Transformer Ratio from 1 to 600
- VT: Voltage Transformer Ratio from 1 to 3000